

ECOTECH

100% GERMAN ENGINEERED 

ECOTECH ADVANCED METERING SYSTEM | CATALOGUE

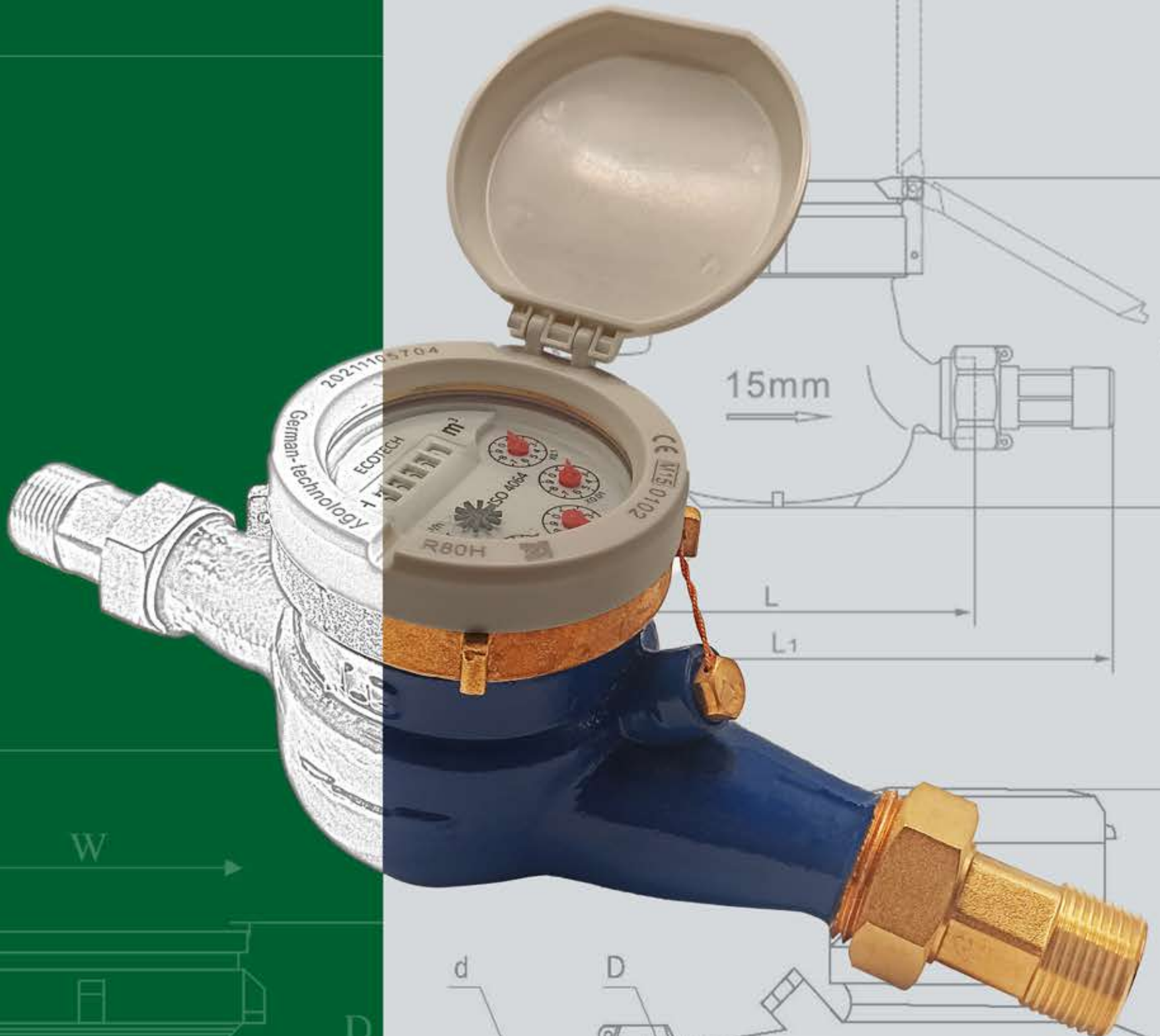

HOT AND COLD WATER METERS

ECOTECH

100% GERMAN ENGINEERED 

ECOTECH WATER METER ADVANTAGES

Ecotech Multi-jet Dry-type Water Meters are the best meters technology can produce. They are created with the best machines together with high-grade quality materials to create a product that will last a lifetime. Because of this, Ecotech Water Meters surpass European standards such as those from the ISO, NSF among others. Take a look of the Ecotech advantage below.



1. Dry-type Technology

Ecotech Water Meter uses Dry-type Technology that is far superior to the typical Wet-type Technology in the market. Thru this technology, Ecotech Water Meters have their registers sealed to ensure the protection of its meter parts from dust and moisture. It also offers better reading due to a clear dial thatt is not affected by moisture.

2. Upgraded Mechanical Transmission and Measuring Chamber

Ecotech Water Meters adapt innovative mechanical transmissions to ensure long-term perfect performance. Together with an upgraded measuring chamber, Ecotech Water Meters have wider clearances thus improving reliability and performance.

3. Superior Raw Material

Ecotech Water Meters are made with the best European raw materials available in the market. It is composed of high quality corrosion-proof copper alloy. Combining the best raw materials with advance German Technology, Ecotech Water Meters are assured to be the best when it comes to quality and performance.



ECOTECH

100% GERMAN ENGINEERED 

ECOTECH SPECIFICATIONS HIGHLIGHTS

DIMENSIONS

Model		DN 15	DN 20	DN 25	DN 32	DN 40	DN 50
Normal size	(mm)	15	20	25	32	40	50
	(inch)	½	¾	1	1¼	1½	2
L - Length without couplings (mm)		165	190	260	260	300	300
L ₁ - Length with couplings (mm)		260	295	380	385	430	450
W - Width (mm)		95	95	100	100	122	145
H - Height (mm)		106	106	115	116	142	178
Weight (kg)		1.5	2.0	2.8	2.8	5.2	8.5

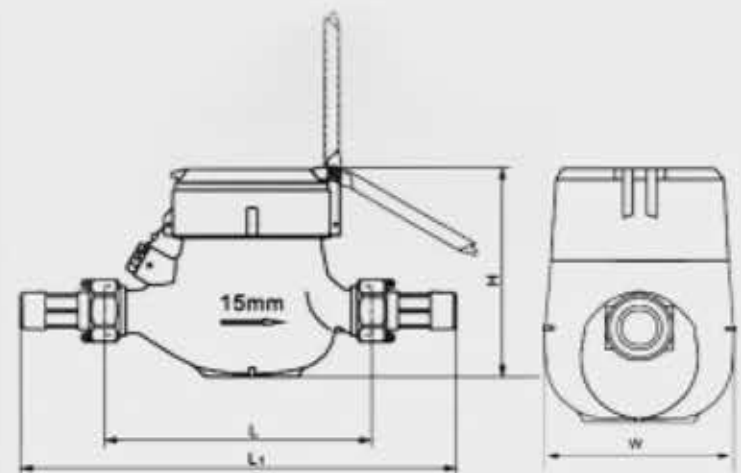

PERFORMANCE DATA

Metrological characteristics according to ISO 4064:2005 (based on OIML R49 EN 14154)

Nominal diameter	mm	DN	15	20	25	32	40	50	
Maximum flowrate	m _v /h	Q _{max}	3.0	5.0	7.0	12	20.0	30.0	
Nominal flowrate	m ³ /h	Q _n	1.5	2.5	3.5	6.0	10.0	15.0	
Transitional flowrate	l/h	Q _t	120	200	280	480	800	1200	
Minimum flowrate	l/h	Q _{min}	30	50	70	120	200	300	
Maximum reading		m ³	99999.9999				999999.9999/999999.999		
Minimum reading		m ³	0.0001				0.0001/0.001		

ECOTECH METER DIAL

- Unit of measurement
- Meater reading
- Sweep han (one complete turn equals 0.1 cubic meters or 22 gallons)
- Low-flow indicator

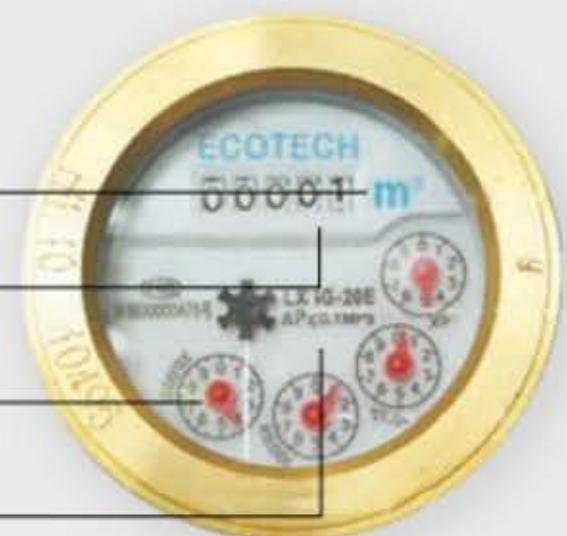

ECOTECH

100% GERMAN ENGINEERED 

ECOTECH ADVANCED METERING SYSTEM | CATALOGUE



EXTREM QUALITAT
UND LEISTUNG
Extreme Quality and Performance



EXCLUSIVELY DISTRIBUTED BY:



 sales@techglobal.com.ph

 [@techglobalinc](https://www.facebook.com/techglobalinc)

 [@techglobalincorporated](https://www.instagram.com/techglobalincorporated)

 Cellphone No.: 0968 871 9888 / 0916 305 9464

 Landline No.: (02) 8659 - 4267 | (02) 8660 - 3723 | (02) 8660 - 3706